

LEARNING OBJECTIVES

- Understand the building science fundamentals of rainwater management, vapor diffusion and air leakage control.
- Understand the use of hygrothermal evaluation of building enclosure assemblies in developing climate appropriate enclosure assemblies.
- Review case studies and understand how small oversights can lead to large failures
- Learn how to evaluate the continuity and detailing of building enclosure control layers
- Understand key risk management steps from design through construction

WALTER P MOORE

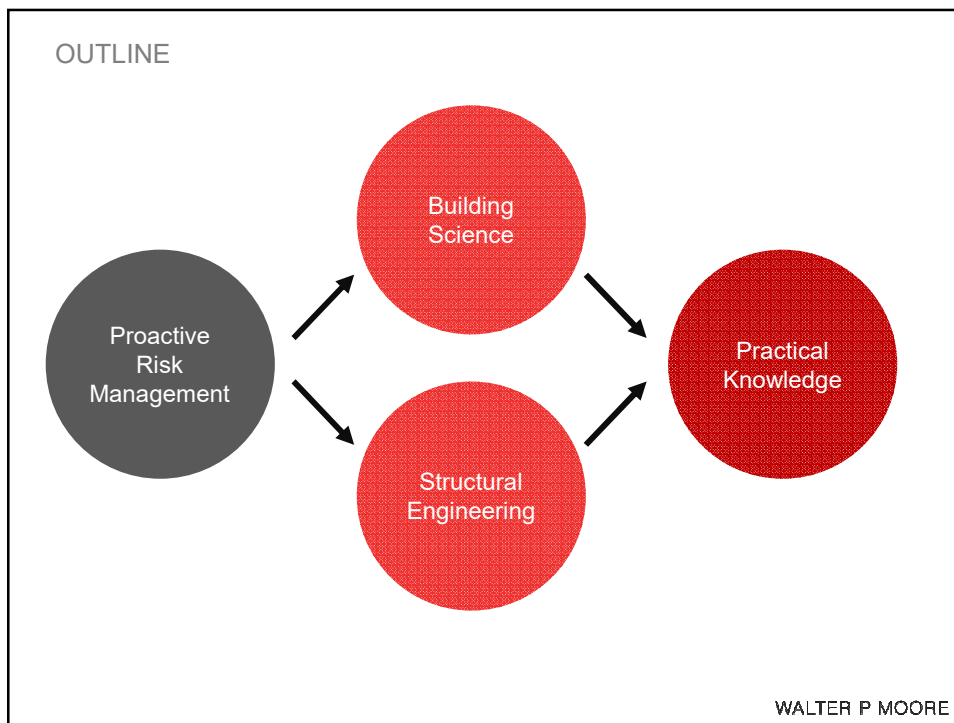



PROACTIVE RISK MANAGEMENT

What does this mean?

Proactive risk management

Controlling or reducing the likelihood of a risk event to shift organization with the odds in our favor

- probability
- consequence

WALTER P MOORE

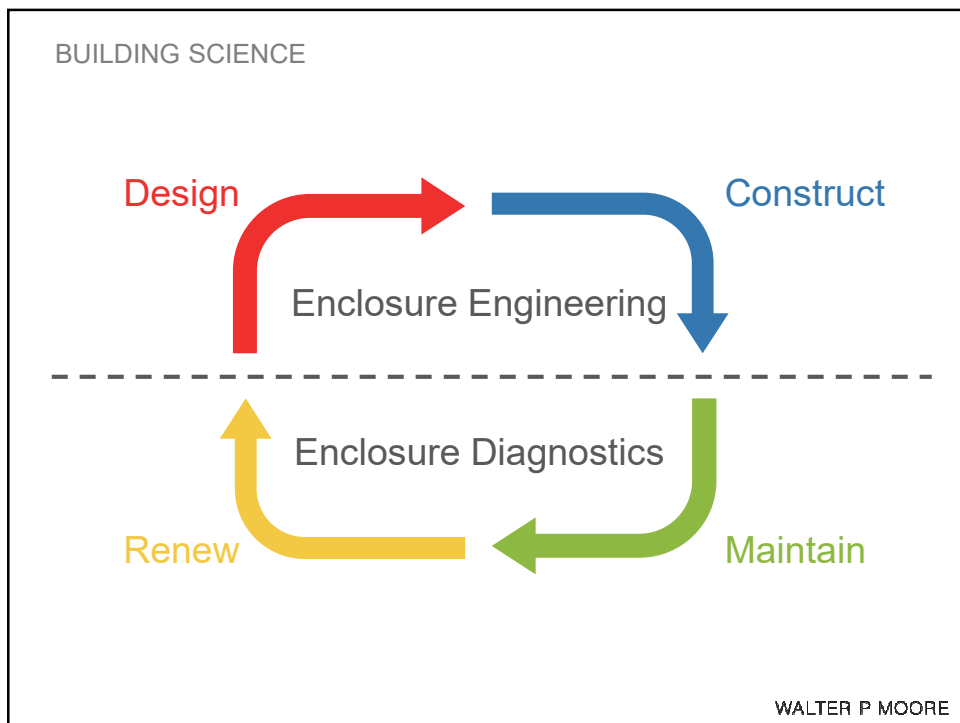
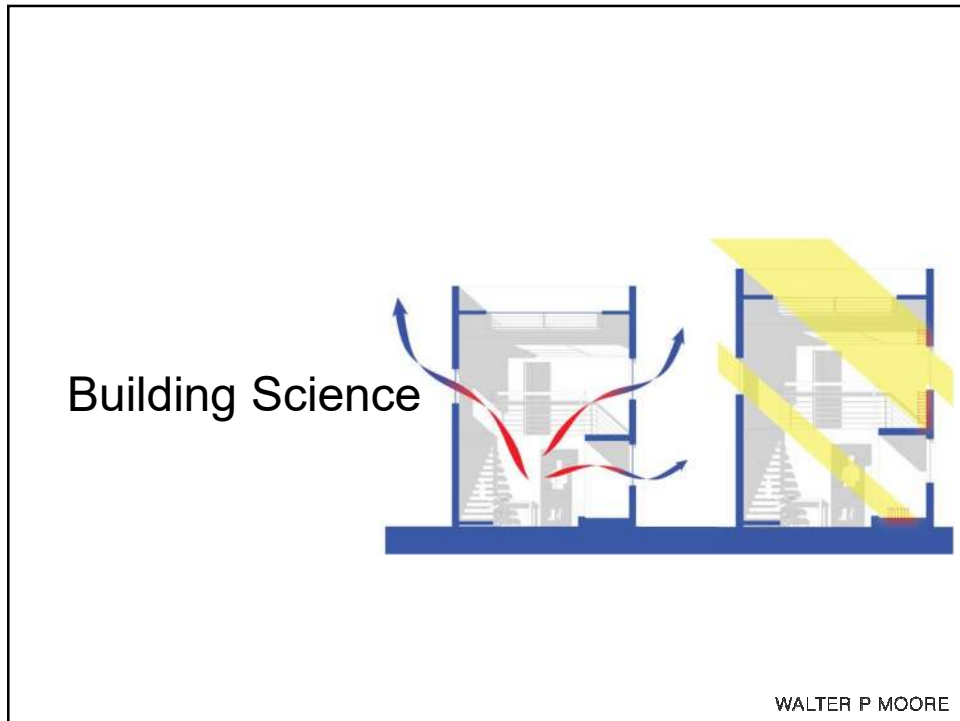

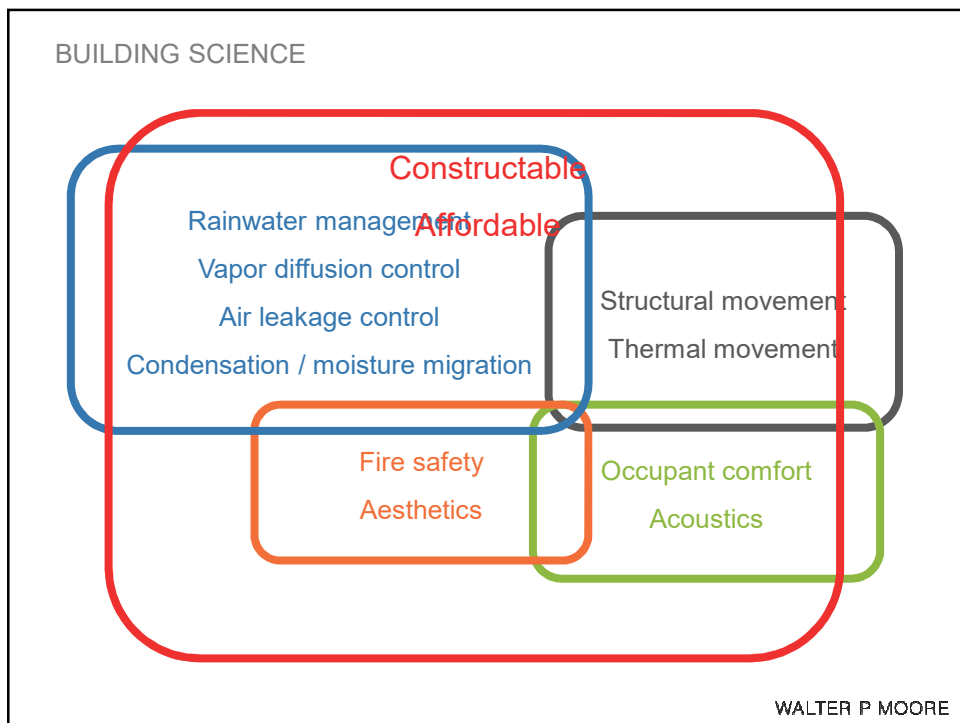
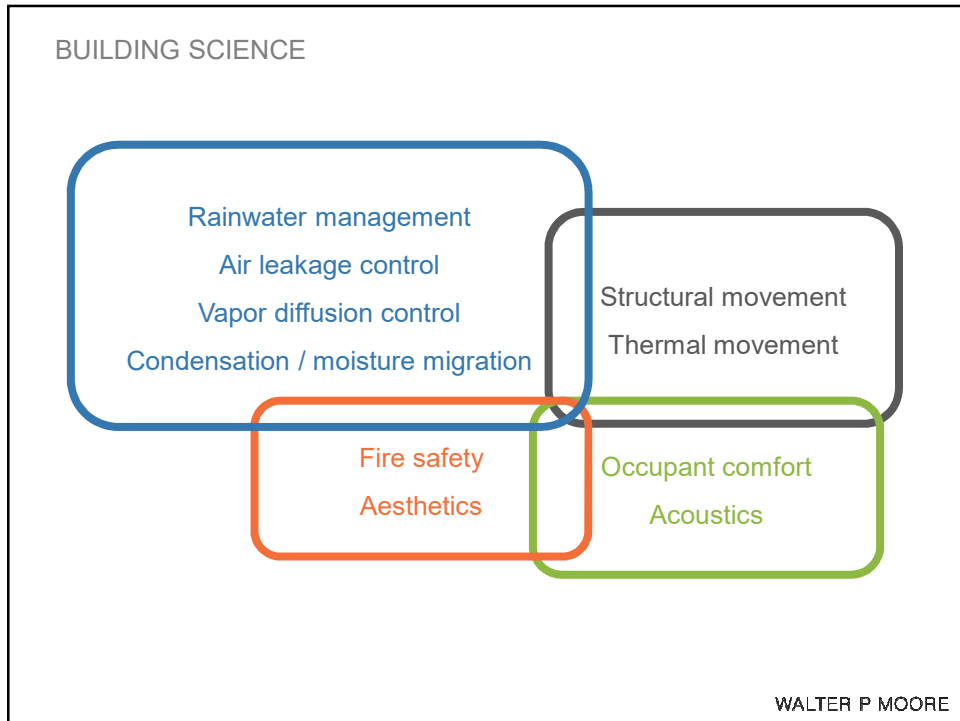

BUILDING SCIENCE

4Ds of Rainwater Management

1. Deflection
2. Drainage
3. Drying
4. Durability

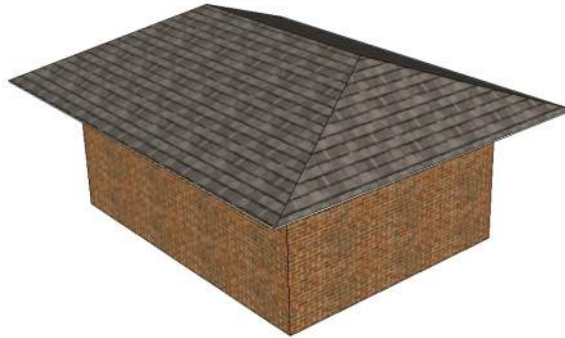

WALTER P MOORE

BUILDING SCIENCE

4Ds of Rainwater Management

1. Deflection
2. Drainage
3. Drying
4. Durability

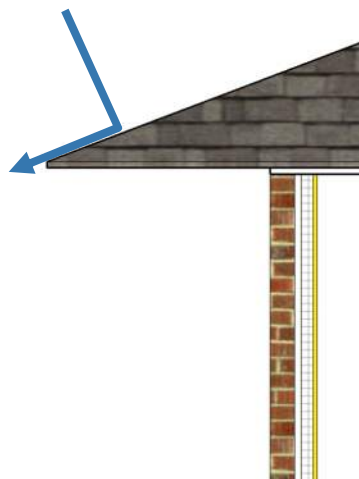

WALTER P MOORE

BUILDING SCIENCE

4Ds of Rainwater Management

1. Deflection
2. Drainage
3. Drying
4. Durability

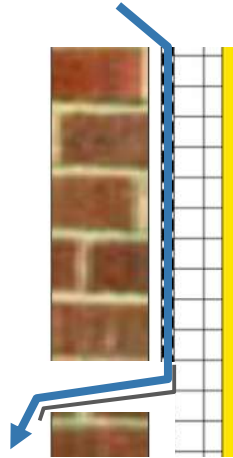

WALTER P MOORE

BUILDING SCIENCE

4Ds of Rainwater Management

1. Deflection
2. Drainage
3. Drying
4. Durability

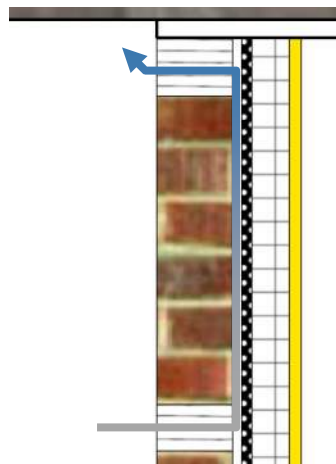

WALTER P MOORE

BUILDING SCIENCE

4Ds of Rainwater Management

1. Deflection
2. Drainage
3. Drying
4. Durability

“No wrong materials...
Just materials used for
the wrong applications”

WALTER P MOORE

BUILDING SCIENCE

Air Leakage Control

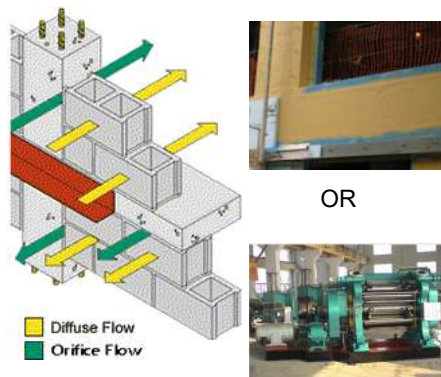
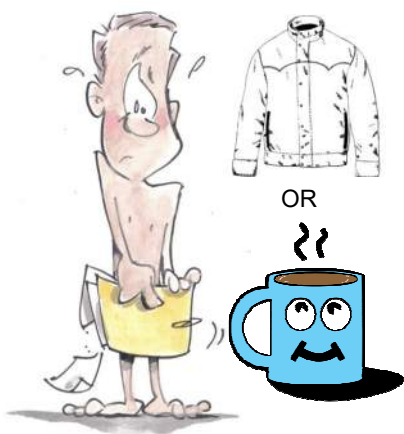

WALTER P MOORE

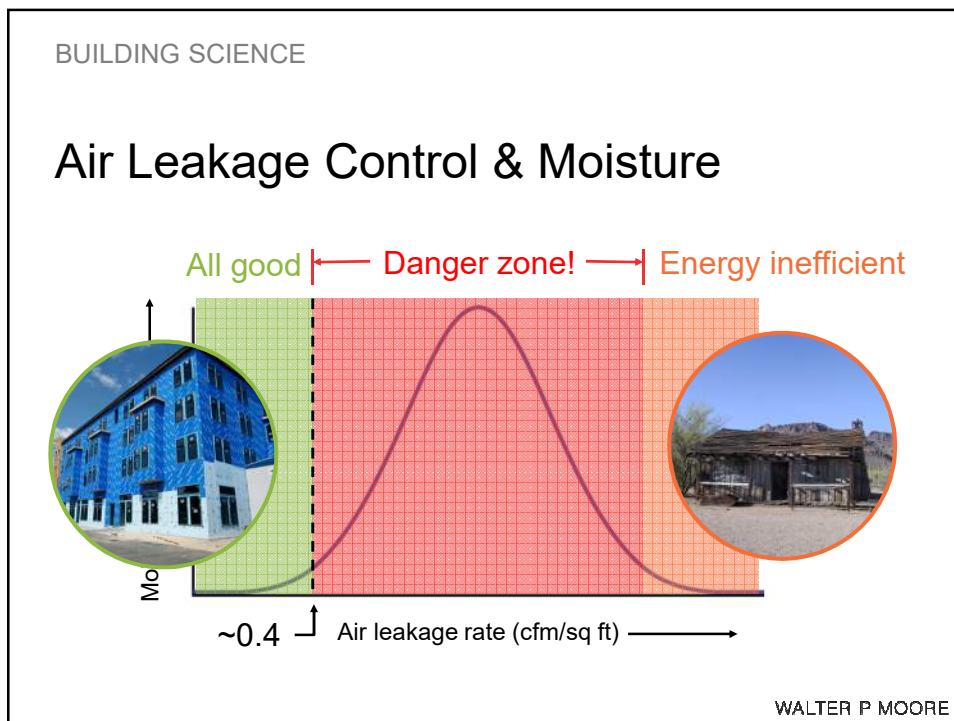
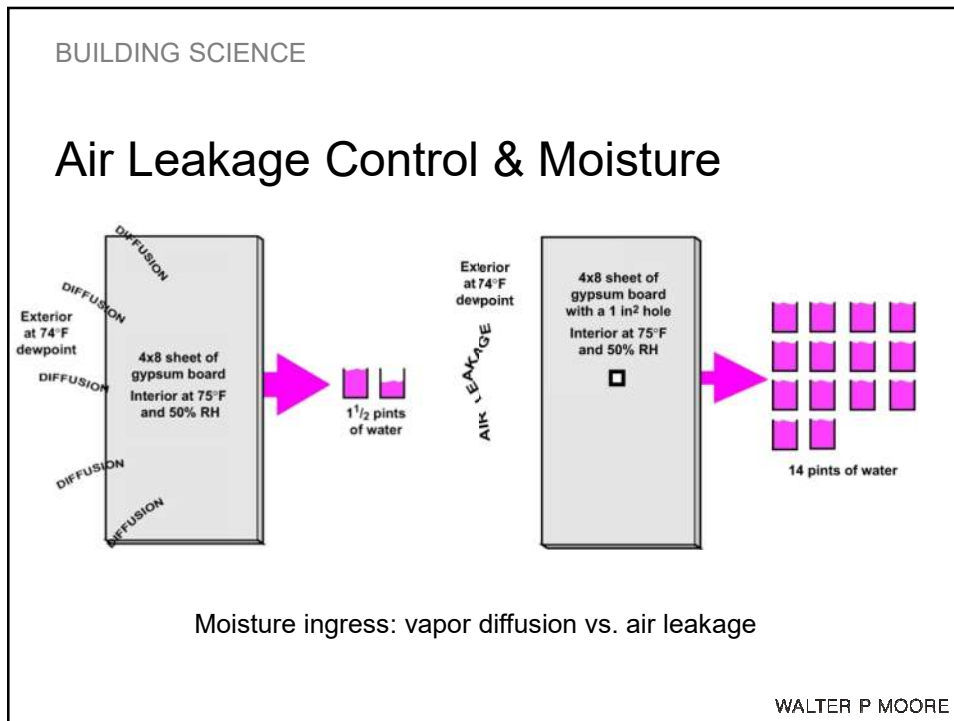

BUILDING SCIENCE

Priorities



Rainwater management



Air leakage control



Vapor diffusion

WALTER P MOORE

BUILDING SCIENCE

Thermal Movement



WALTER P MOORE

Case Studies

When things go wrong



WALTER P MOORE

CASE STUDIES

Parkridge Building Re-Cladding

Investigation

Using our diagnostics toolbox



WALTER P MOORE

CASE STUDIES – PARKRIDGE BUILDING RE-CLADDING

Investigation Toolbox

- Document review
- Facility management interviews



WALTER P MOORE

CASE STUDIES – PARKRIDGE BUILDING RE-CLADDING

Investigation Toolbox

- Document review
- Facility management interviews
- Visual survey of interior & exterior



WALTER P MOORE

CASE STUDIES – PARKRIDGE BUILDING RE-CLADDING

Investigation Toolbox

- Document review
- Facility management interviews
- Visual survey of interior & exterior
- Nondestructive evaluation

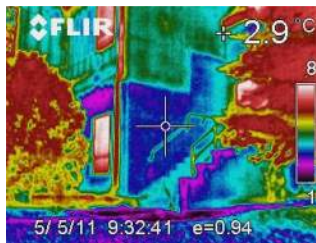

WALTER P MOORE

CASE STUDIES – PARKRIDGE BUILDING RE-CLADDING

Investigation Toolbox

- Document review
- Facility management interviews
- Visual survey of interior & exterior
- Nondestructive evaluation
- Destructive testing & exploratory openings



WALTER P MOORE

CASE STUDIES – PARKRIDGE BUILDING RE-CLADDING

Investigation Toolbox

- Document review
- Facility management interviews
- Visual survey of interior & exterior
- Nondestructive evaluation
- Destructive testing & exploratory openings
- **Water testing**



WALTER P MOORE

CASE STUDIES – PARKRIDGE BUILDING RE-CLADDING

Investigation Toolbox

- Document review
- Facility management interviews
- Visual survey of interior & exterior
- Nondestructive evaluation
- Destructive testing & exploratory openings
- Water testing
- **Indoor environmental conditions testing**



WALTER P MOORE

CASE STUDIES – PARKRIDGE BUILDING RE-CLADDING

Investigation Toolbox

- Document review
- Facility management interviews
- Visual survey of interior & exterior
- Nondestructive evaluation
- Destructive testing & exploratory openings
- Water testing
- Indoor environmental conditions testing
- Building envelope analysis

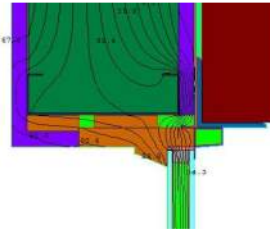
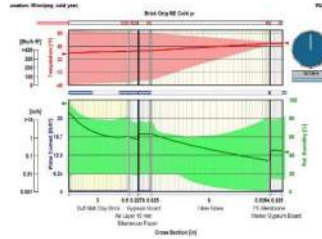

WALTER P MOORE

CASE STUDIES – PARKRIDGE BUILDING RE-CLADDING



WALTER P MOORE

CASE STUDIES

University of Texas Medical Building

Recladding

Brick, curtain wall, metal rain screen panels, cast stone



WALTER P MOORE

CASE STUDIES – UTMB

What's Wrong Here?

Failure at concrete beam

Distress at sloped brick sills

Outward displacement of brick veneer



WALTER P MOORE

CASE STUDIES – UTMB

What's Wrong Here?

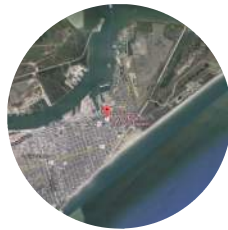

Coastal Environment

Corroded

- reinforcement steel
- shelf angles and lintels
- brick ties

→ Failure

WALTER P MOORE

CASE STUDIES – UTMB

How To Fix It?

1. Brick demolition
 2. Backup wall remediation
 3. Air/water/vapor barrier
 4. New cladding
- Unreinforced CMU is structurally deficient
 - Cannot anchor new cladding to unreinforced CMU
 - New exterior aluminum structure anchored to existing floor slabs

WALTER P MOORE

CASE STUDIES – UTMB

How To Fix It?



Replace brick veneer & install air/water barrier

Metal cladding with exterior aluminum frame

Partial infill & curtain wall

WALTER P MOORE

CASE STUDIES – UTMB



WALTER P MOORE

Case Studies

Pro-Active Diagnostics
Solve problems before they become problems

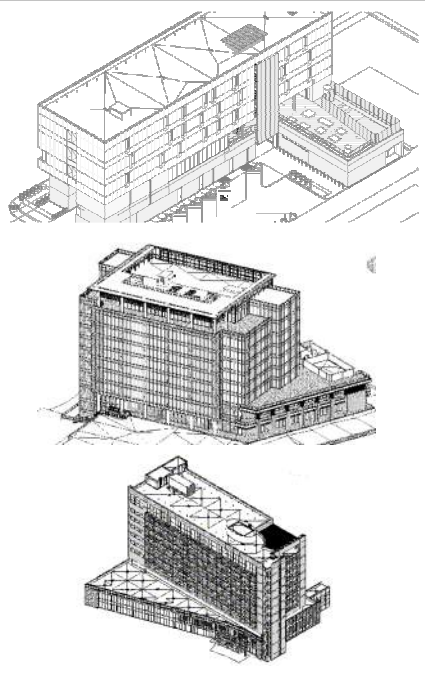

WALTER P MOORE

CASE STUDIES

How To Do It Right?

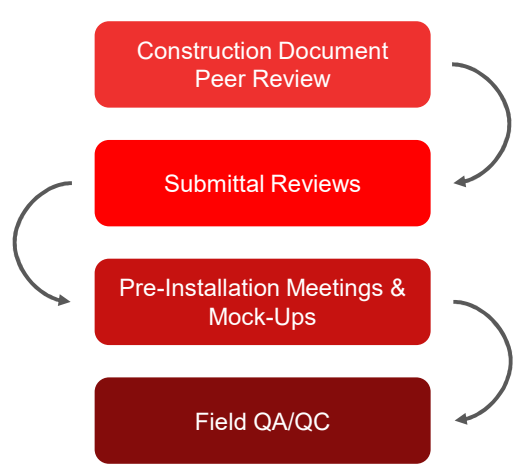

Construction Document Peer Review

Submittal Reviews

Pre-Installation Meetings & Mock-Ups

Field QA/QC

WALTER P MOORE

CASE STUDIES

Men's Center

Peer Review

Drawing and specification review prior to construction

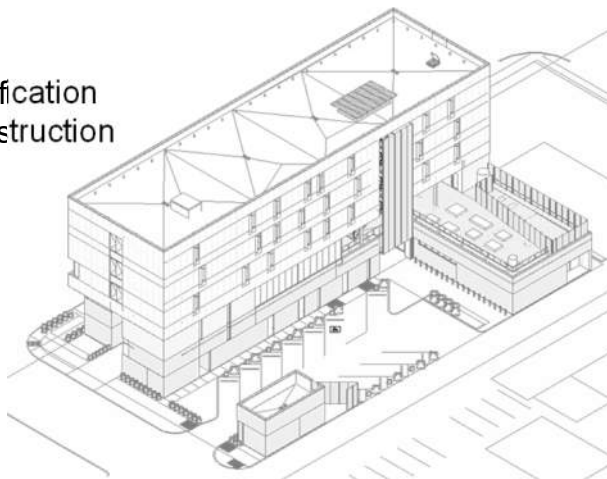

WALTER P MOORE

CASE STUDIES – MEN'S CENTER

What's Inside, What's Outside?

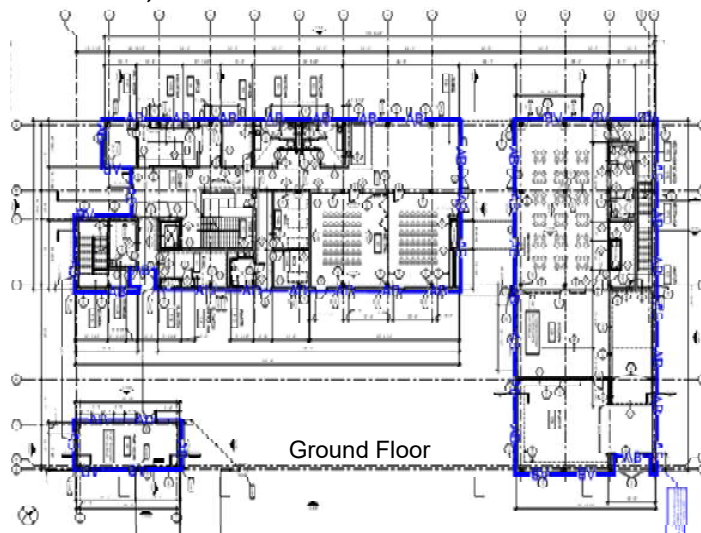

WALTER P MOORE

CASE STUDIES – MEN'S CENTER

What's Inside, What's Outside?

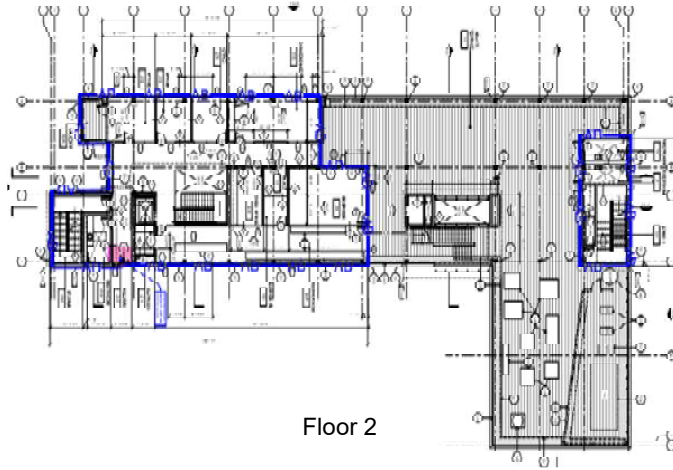

Floor 2

WALTER P MOORE

CASE STUDIES – MEN'S CENTER

What's Inside, What's Outside?

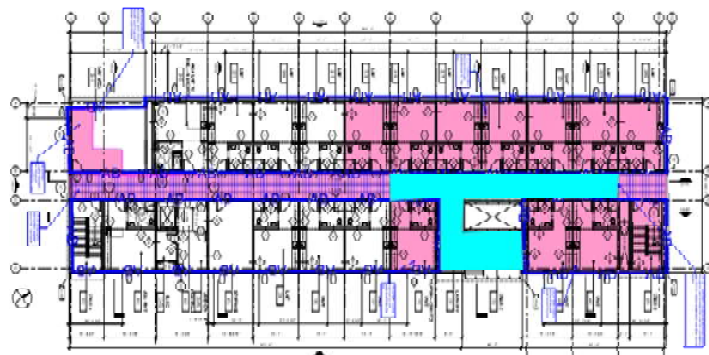

Floor 3

WALTER P MOORE

CASE STUDIES – MEN'S CENTER

What's Inside, What's Outside?

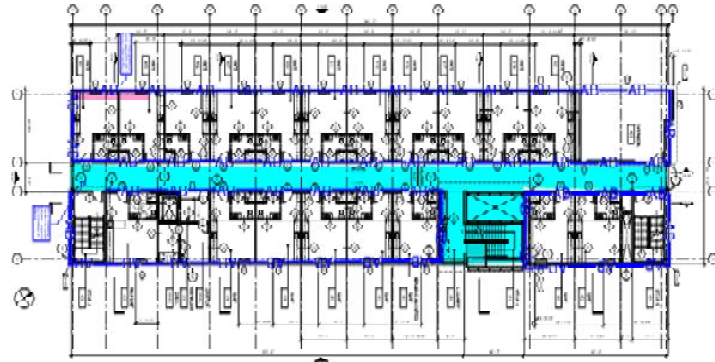

Floor 4

WALTER P MOORE

CASE STUDIES – MEN'S CENTER

What's Inside, What's Outside?

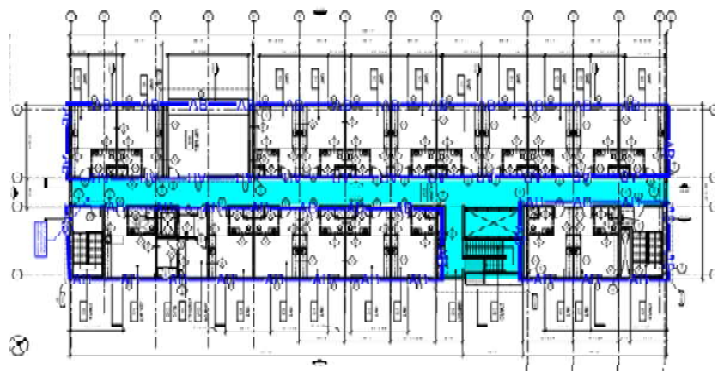

Floor 5

WALTER P MOORE

CASE STUDIES – MEN'S CENTER

What's Inside, What's Outside?

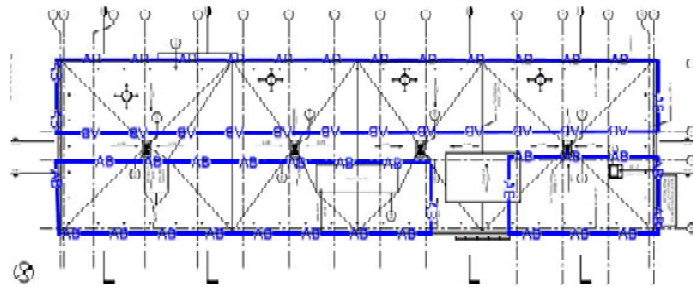

Roof

WALTER P MOORE

CASE STUDIES – MEN'S CENTER

Connect the Dots

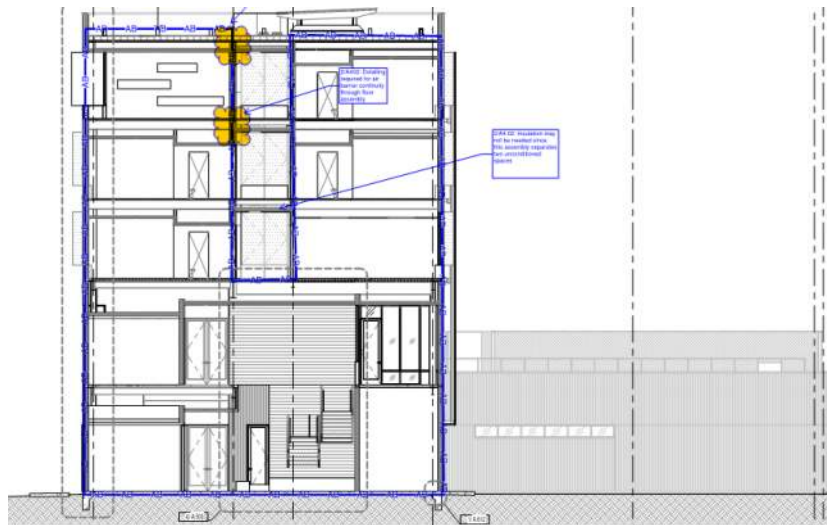

WALTER P MOORE

CASE STUDIES – MEN'S CENTER

Connect the Dots

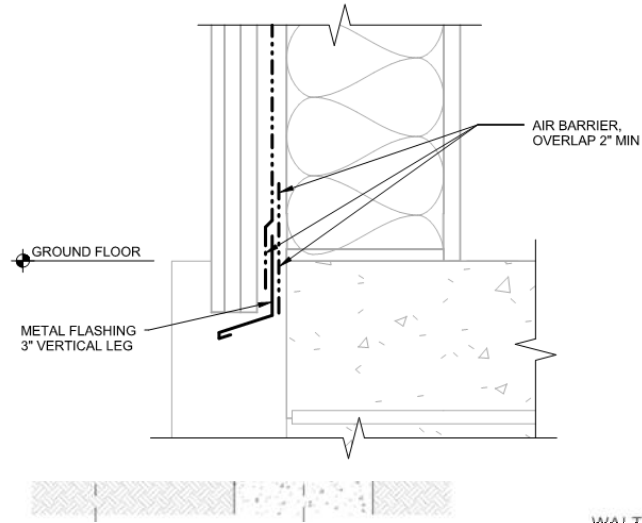

CASE STUDIES – MEN'S CENTER

Connect the Dots

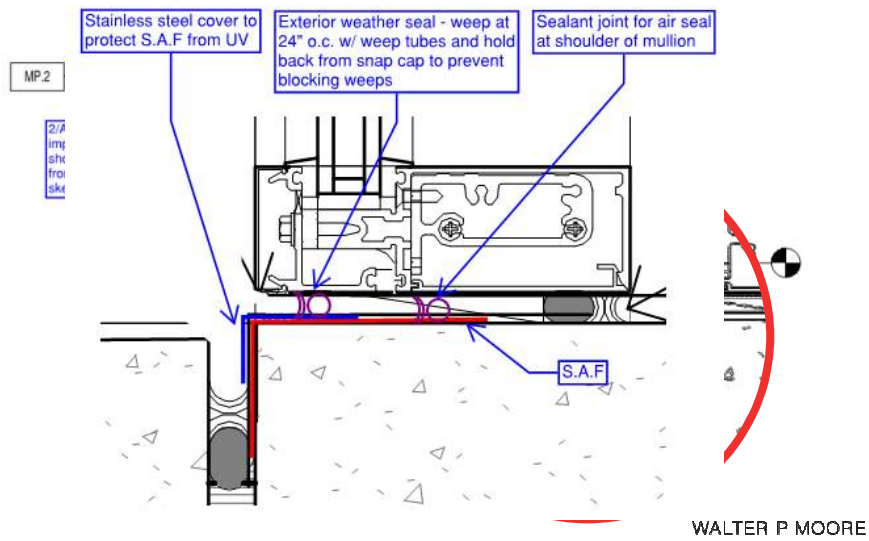

CASE STUDIES

One Braves Plaza

Complex interfaces

Office tower
Shotcrete wall

Reflectivity Study

Occupant comfort

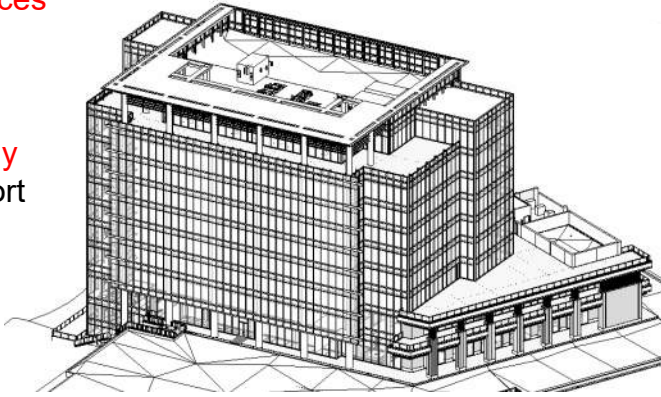

WALTER P MOORE

CASE STUDIES – ONE BRAVES PLAZA

Complex Interfaces – Office Tower

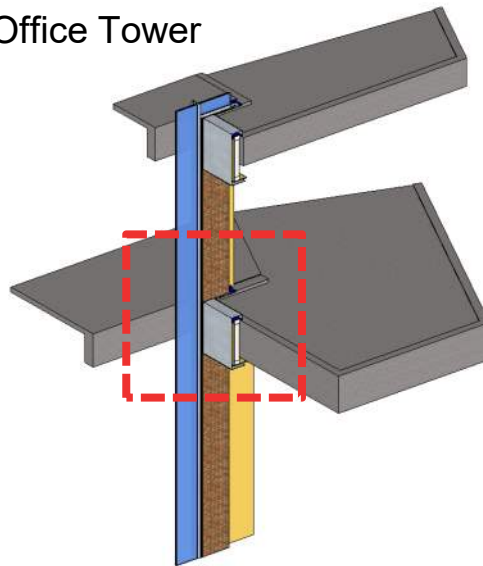
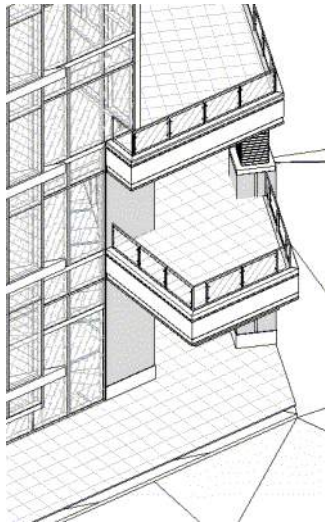

WALTER P MOORE

CASE STUDIES – ONE BRAVES PLAZA

Complex Interfaces – Office Tower

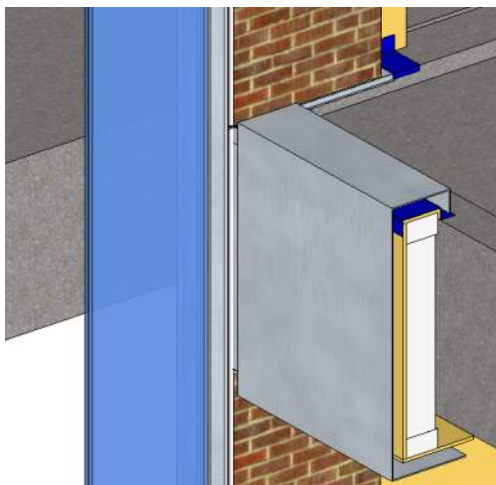

Virtual Mockup

WALTER P MOORE

CASE STUDIES – ONE BRAVES PLAZA

Complex Interfaces – CIP deck and shotcrete wall

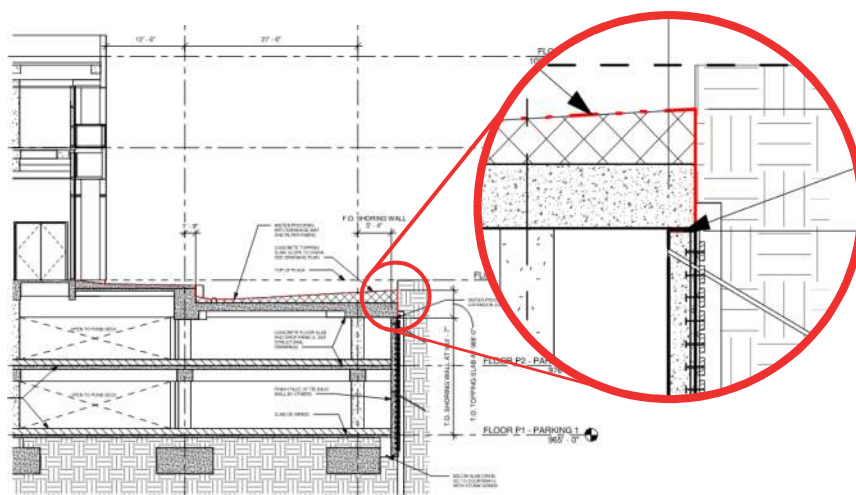

WALTER P MOORE

CASE STUDIES – ONE BRAVES PLAZA

Complex Interfaces – Shotcrete Wall

Vertical Expansion Joint

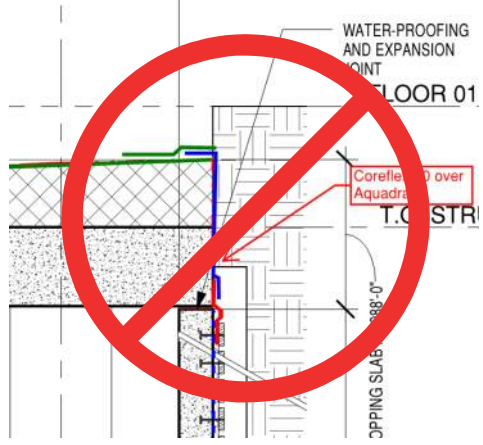

Redefine the Problem

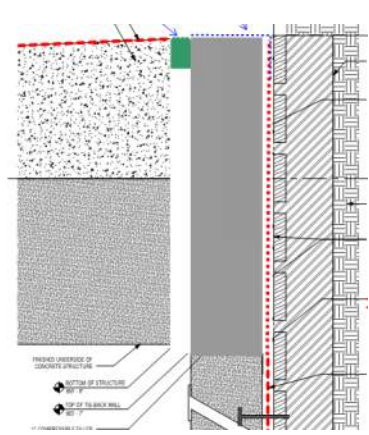

WALTER P MOORE

CASE STUDIES – ONE BRAVES PLAZA

Complex Interfaces – Shotcrete Wall

Collaboration

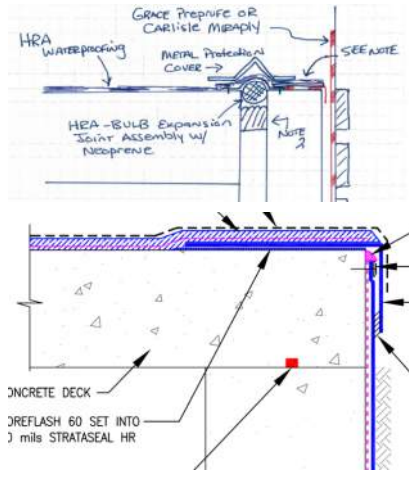

Solution

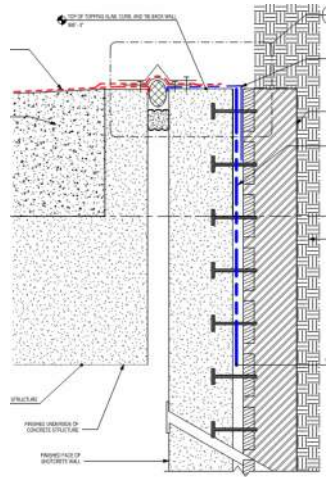

WALTER P MOORE

CASE STUDIES – ONE BRAVES PLAZA

Complex Interfaces – Shotcrete Wall



WALTER P MOORE

CASE STUDIES – ONE BRAVES PLAZA

Complex Interfaces – Shotcrete Wall

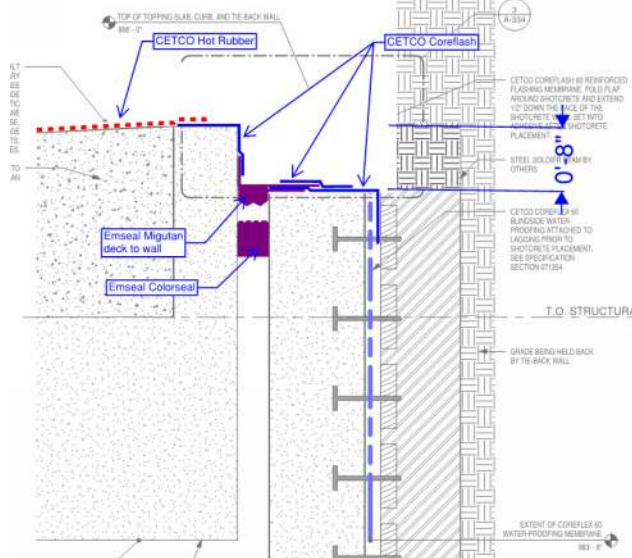

WALTER P MOORE

CASE STUDIES – ONE BRAVES PLAZA

Reflectivity Study

Walter P Moore - Diagnostics
Solar Reflectivity Analysis

Site Location,
ATLANTA, GA, USA,
33.65, !Latitude
-84.43, !Longitude
-5.0, !Time Zone
315.0, !Elevation



WALTER P MOORE

CASE STUDIES

Jersey Shore UMC

Detailing

Continuity of enclosure at
complex 3D interfaces

Thermal Bridging Study

Occupant comfort

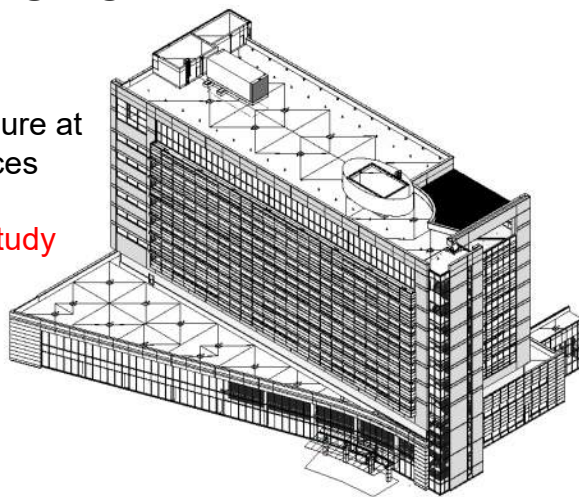

WALTER P MOORE

CASE STUDIES – JERSEY SHORE UMC

Challenges

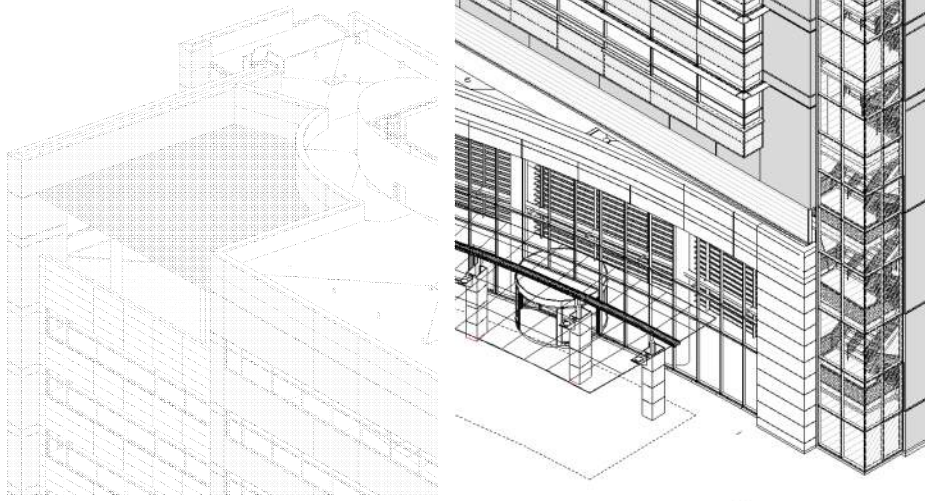

WALTER P MOORE

CASE STUDIES – JERSEY SHORE UMC

Detailing

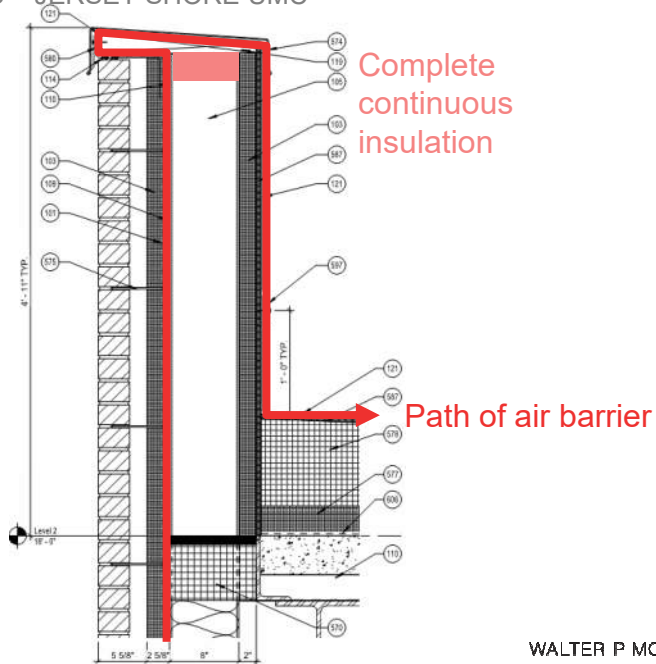

WALTER P MOORE

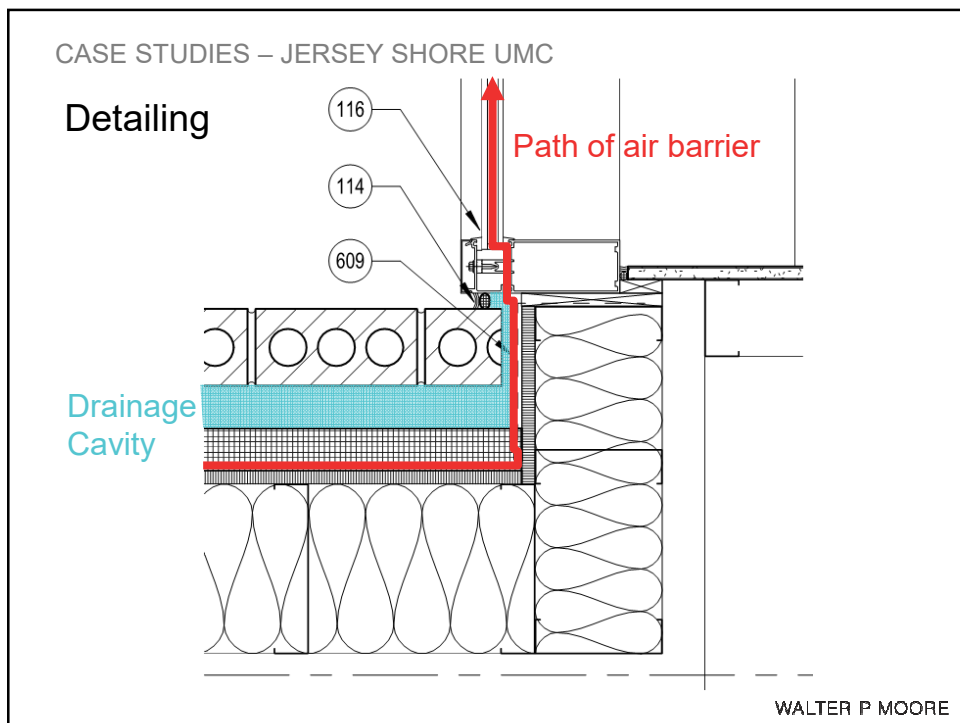
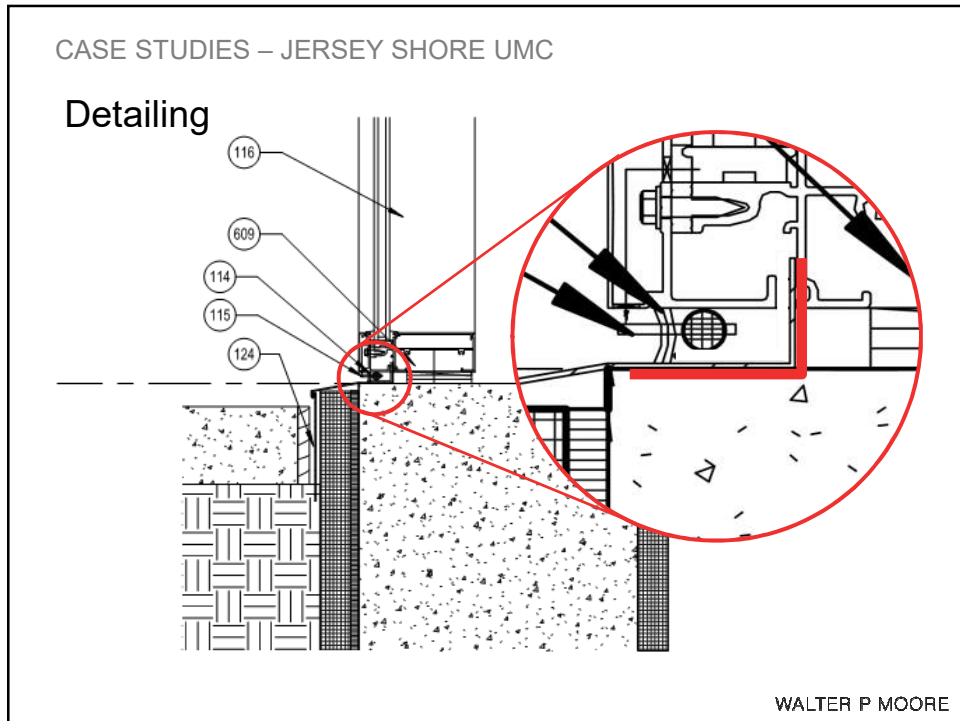

CASE STUDIES – JERSEY SHORE UMC

Thermal Bridging Study

Original Detail

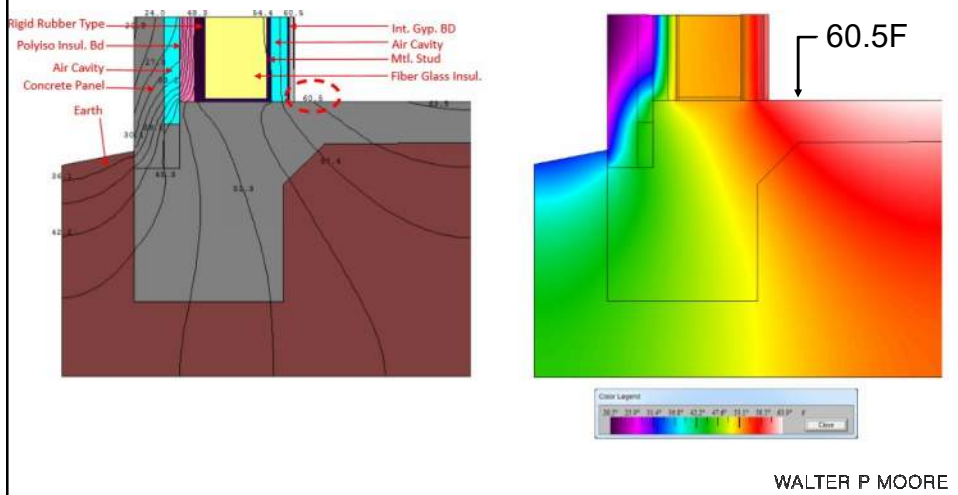

CASE STUDIES – JERSEY SHORE UMC

Thermal Bridging Study

Modified Foundation & Insulation

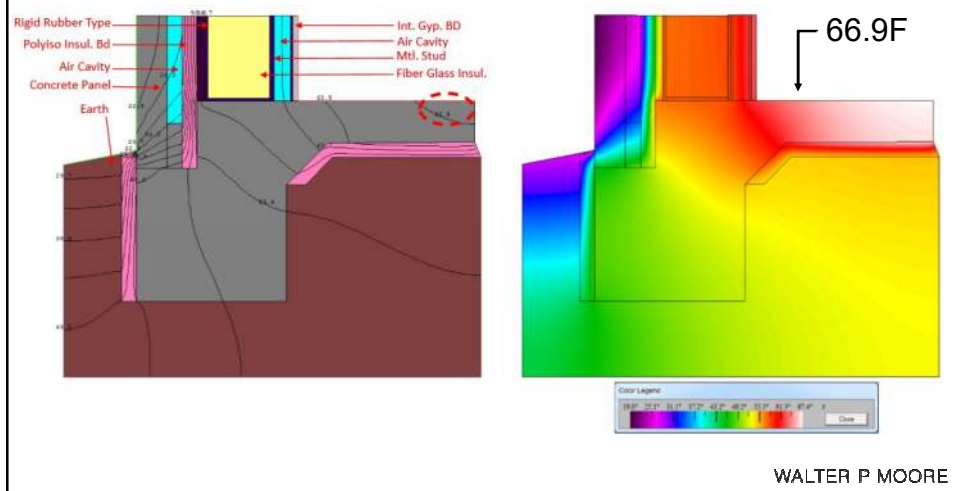

QUALITY ASSURANCE TESTING

Water Testing



AAMA 501.2
Nozzle Test



ASTM E1105
Spray Rack Test

WALTER P MOORE

Summary

SUMMARY

MIND THE GAP

WALTER P MOORE

SUMMARY

Indoor Environmental Quality Credit:
Enhanced Indoor Air Quality Strategies

“Increase breathing zone outdoor air ventilation rates to all occupied spaces by at least 30% above the minimum rates as determined in EQ Prerequisite Minimum Indoor Air Quality Performance.

= a recipe for disaster in humid climate



The road to hell is paved with good intentions

WALTER P MOORE

